

PELE DE  
**VIDRO**

Catálogo Técnico

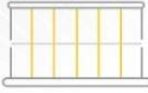

01 PERFIS LINHA PELE DE VIDRO

**NOTAS IMPORTANTES**

- Fornecimento dos Perfis em Barra de 6000mm.
- Para as dimensões fora destes padrões o lote mínimo por item é de 150Kg.
- Perfis e Acessórios, sujeito a alterações sem prévio aviso

Rev. 04/23

Código	Descrição	Pág.
PV-001	Arremate	04
PV-002	Fixador Frontal	04
PV-003	Coluna	05
PV-004	Coluna de Reforço	06
PV-005	Fixador de Vidro	13
PV-006	Tampa da Coluna	13
PV-007	Coluna	13
PV-008	Ancoragem	14
PV-009	Suporte da Coluna	14
PV-010	Base de Fixação	04
PV-011	Chumbador	05
PV-012	Tampa da Coluna Intermediaria	10
PV-013	Fixador Frontal	10
PV-014	Coluna Intermediaria	10
PV-015	Coluna	10
MM-011	Tampa da Coluna Central	06
GA-010	Perfil Ripado 38 x 50mm	11
GA-011	Tampa do Perfil Ripado 38 x 50mm	11



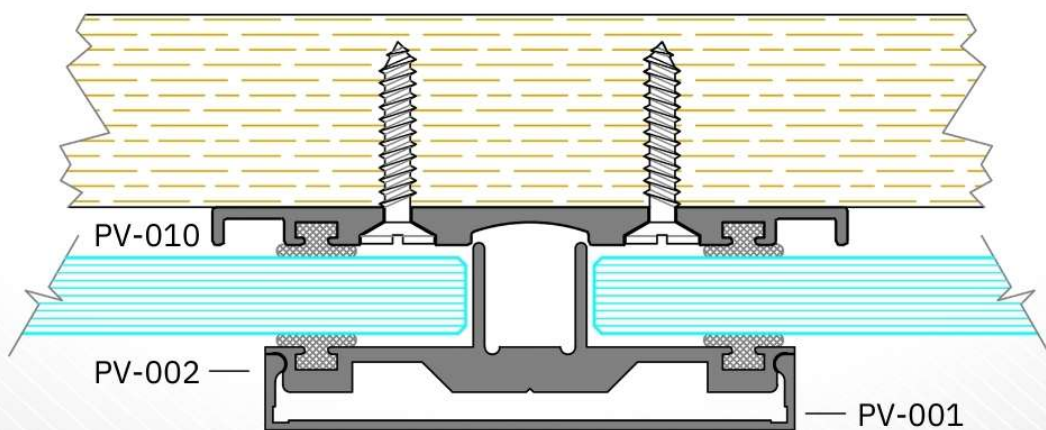
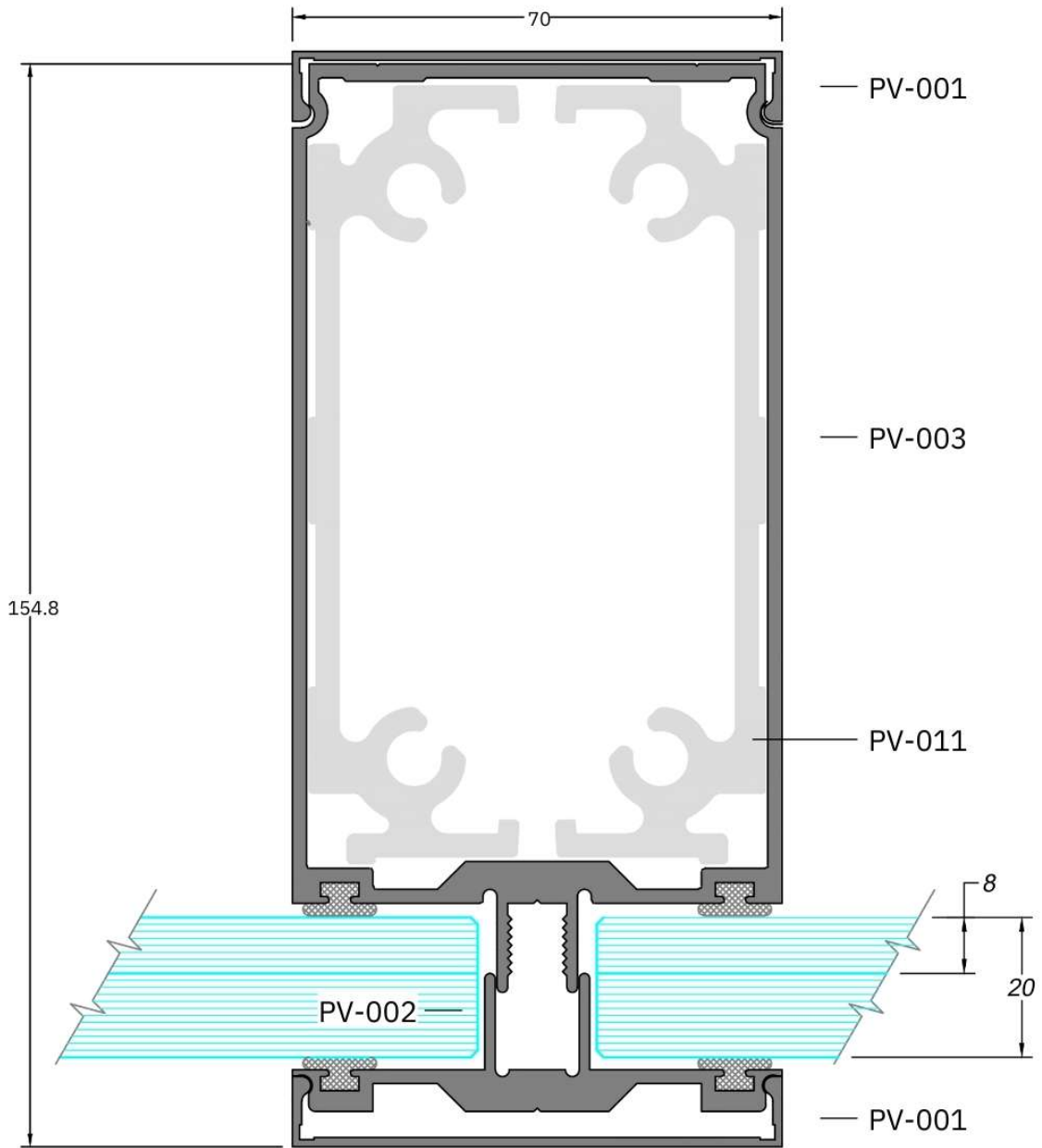
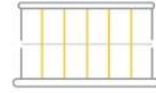

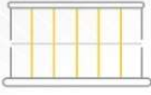

PELE DE  
VIDRO

**ALUMP**<sup>®</sup>  
Extrusão de Alumínio

**VIPEL**<sup>®</sup>  
Vidros e Alumínios

3

PELE DE  
VIDRO  
V-004

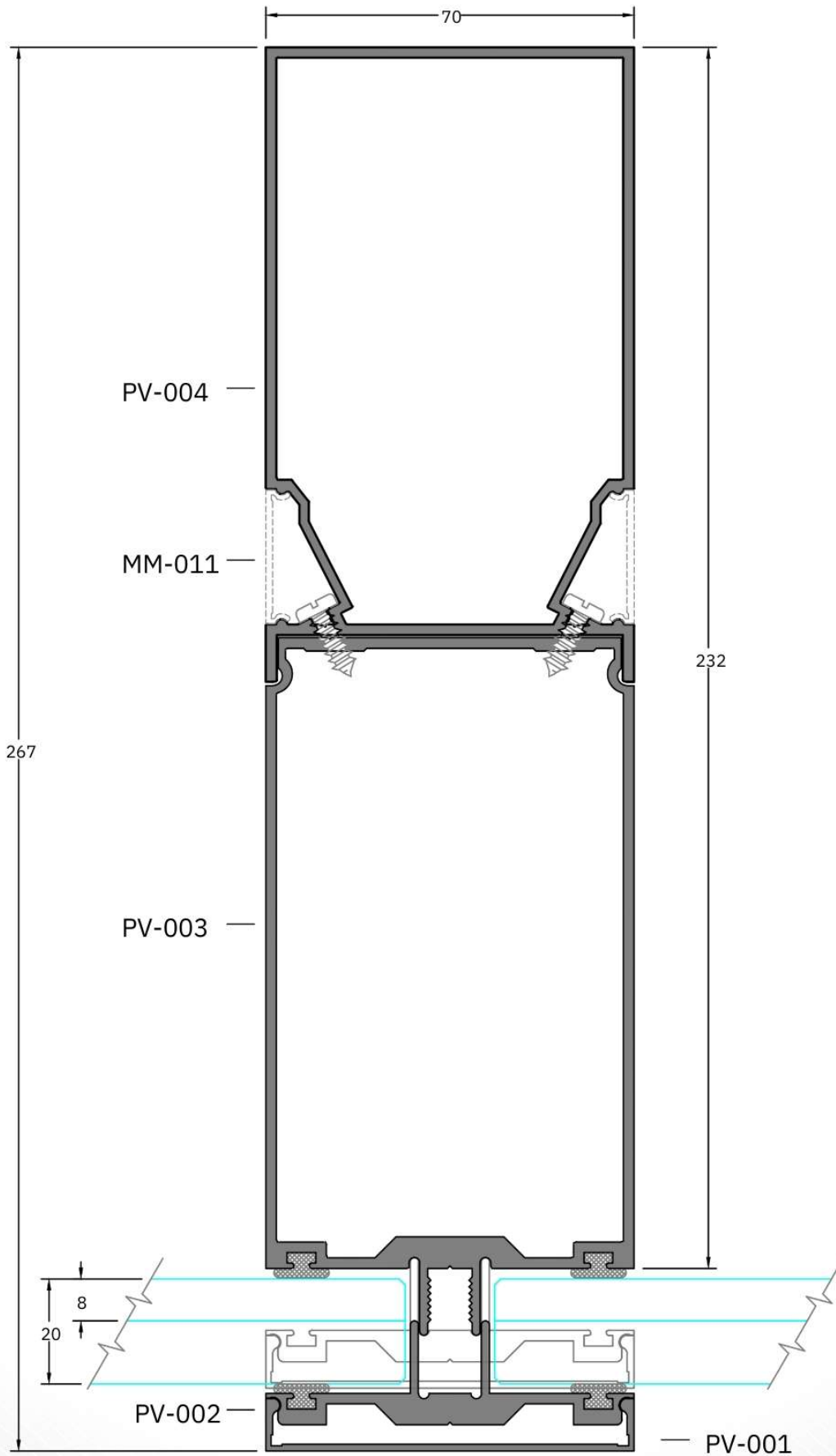

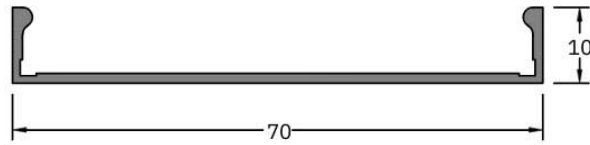
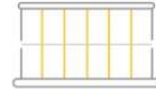

Peso (Kg/m)	Superfície (mm <sup>2</sup> /mm)		Inércia (mm <sup>2</sup> /mm)	
	Área	Perímetro	Jx mm <sup>4</sup>	Jy mm <sup>4</sup>
0.316	116.86	182.22	869.34	67386.75

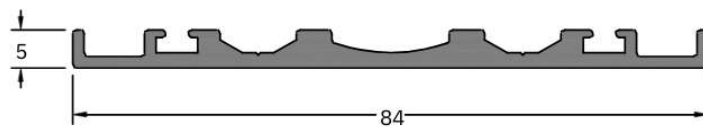

Peso (Kg/m)	Superfície (mm <sup>2</sup> /mm)		Inércia (mm <sup>2</sup> /mm)	
	Área	Perímetro	Jx mm <sup>4</sup>	Jy mm <sup>4</sup>
0,663	244.80	219.37	434.34	132344.64

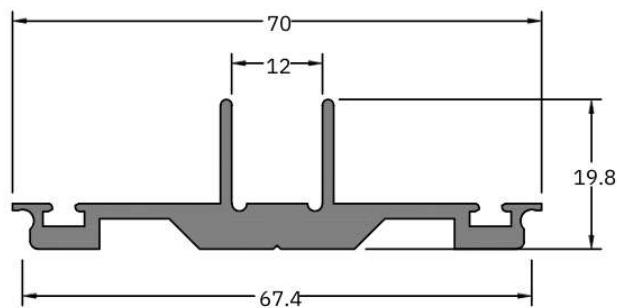

Peso (Kg/m)	Superfície (mm <sup>2</sup> /mm)		Inércia (mm <sup>2</sup> /mm)	
	Área	Perímetro	Jx mm <sup>4</sup>	Jy mm <sup>4</sup>
0.849	313.47	239.37	4724.70	91938.74

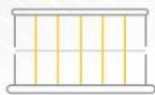

PELE DE  
VIDRO

**ALUMP**<sup>®</sup>  
Extrusão de Alumínio

**VIPEL**<sup>®</sup>  
Vidros e Alumínios

5

PELE DE  
VIDRO  
V-004

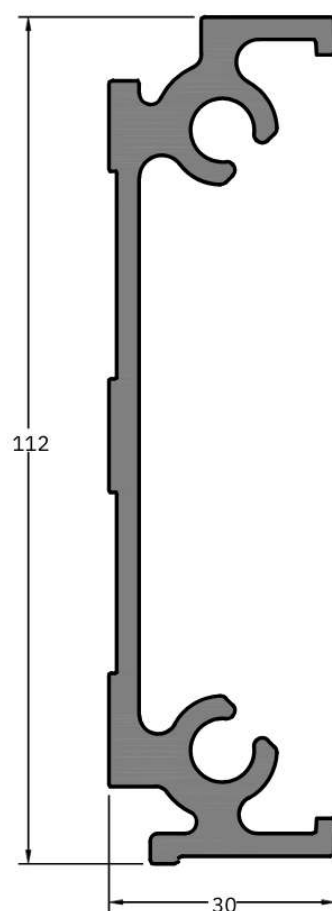
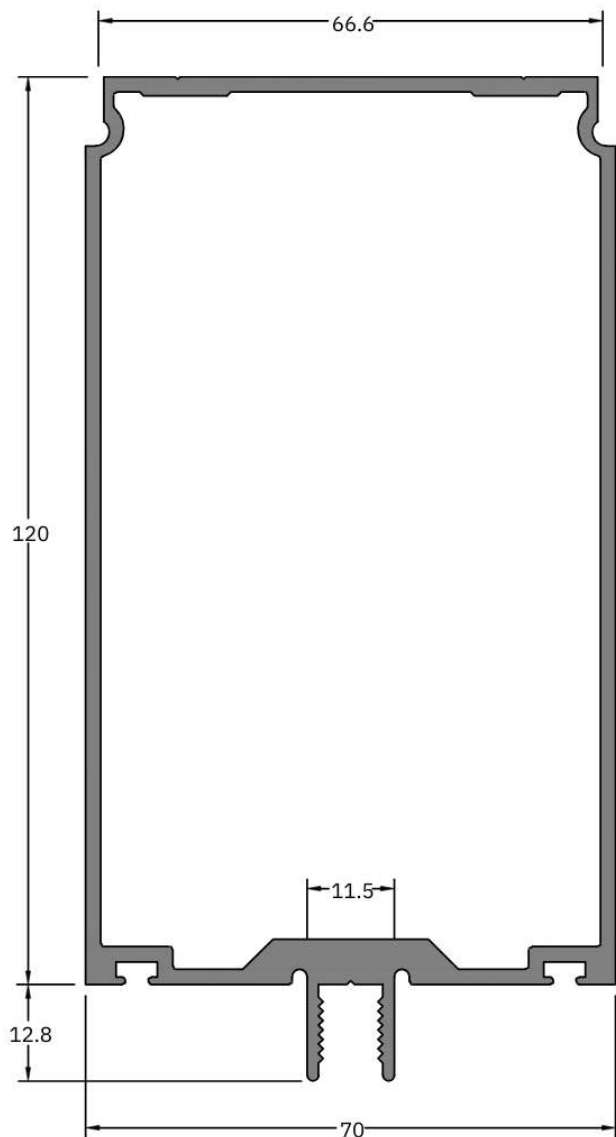

PV-003

Coluna

Peso (Kg/m)	Superfície (mm <sup>2</sup> /mml)		Inércia (mm <sup>2</sup> /mml) <sup>4</sup>	
	Área	Perímetro	Jx mm <sup>2</sup>	Jy mm <sup>2</sup>
2.465	909.68	830.75	1963727.08	71430.22

PV-011

Chumbador

Peso (Kg/m)	Superfície (mm <sup>2</sup> /mml)		Inércia (mm <sup>2</sup> /mml) <sup>4</sup>	
	Área	Perímetro	Jx mm <sup>2</sup>	Jy mm <sup>2</sup>
2.087	770.25	406.28	1241983.83	46720.28

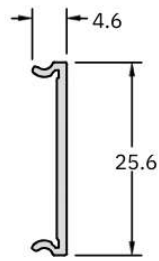

**MM-011** Tampa da Coluna Central

Peso (Kg/m)	Superfície (mm <sup>2</sup> /mml)		Inércia (mm <sup>2</sup> /mml)	
	Área	Perímetro	Jx mm <sup>4</sup>	Jy mm <sup>4</sup>
0,107	39.49	68.51	2662.30	38.49

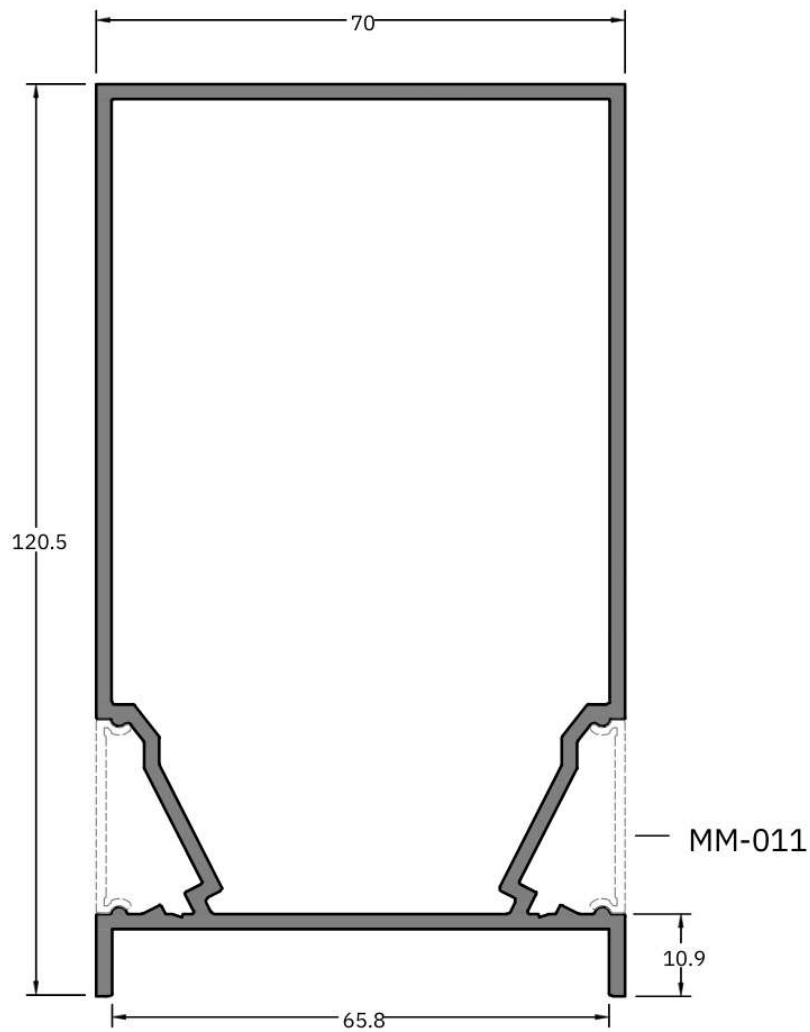

**PV-004** Coluna de Reforço

Peso (Kg/m)	Superfície (mm <sup>2</sup> /mml)		Inércia (mm <sup>2</sup> /mml)	
	Área	Perímetro	Jx mm <sup>4</sup>	Jy mm <sup>4</sup>
2.144	791.42	780.02	1447407.49	632692.04



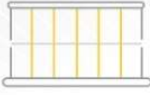

PELE DE  
VIDRO

**ALUMP**<sup>®</sup>  
Extrusão de Alumínio

**VIPEL**<sup>®</sup>  
Vidros e Alumínios

7

PELE DE  
VIDRO  
V-004

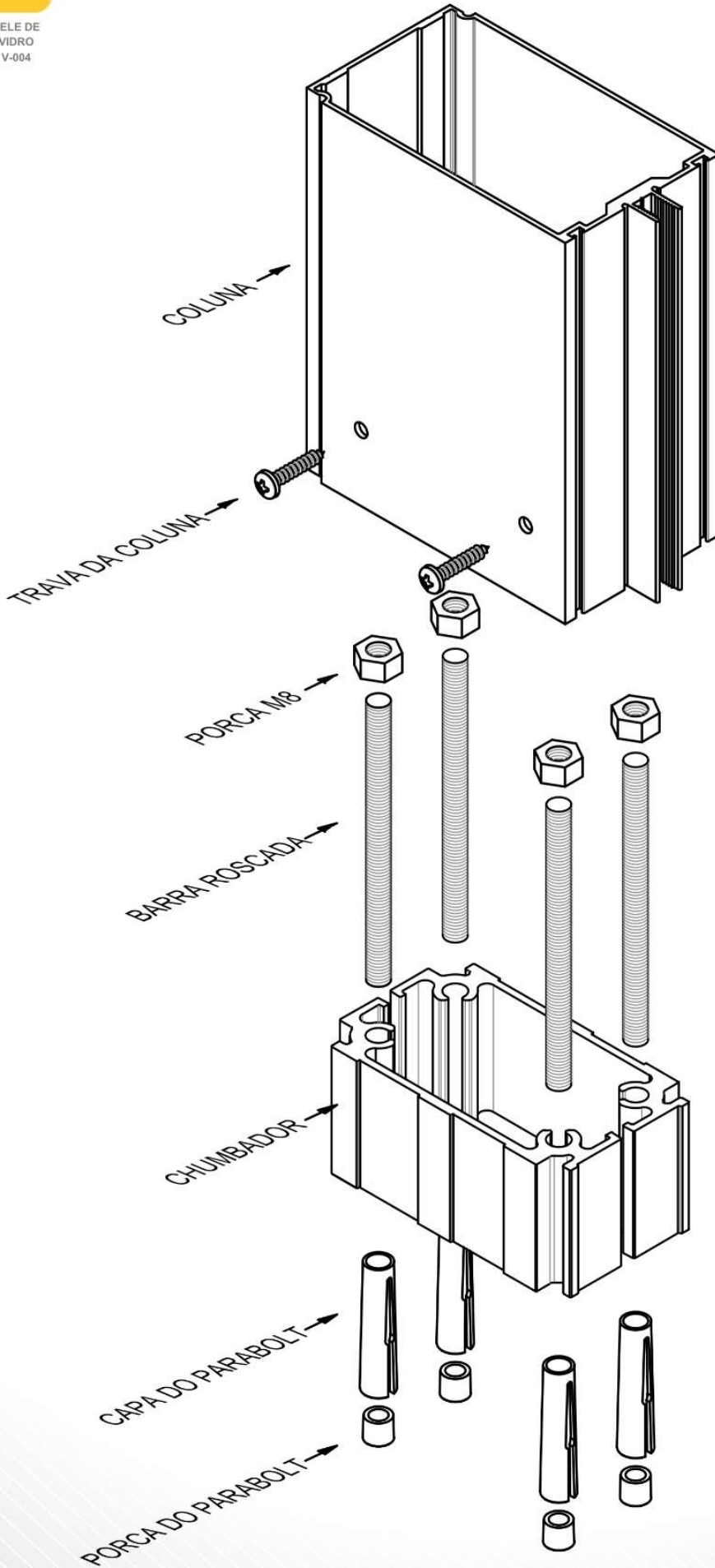



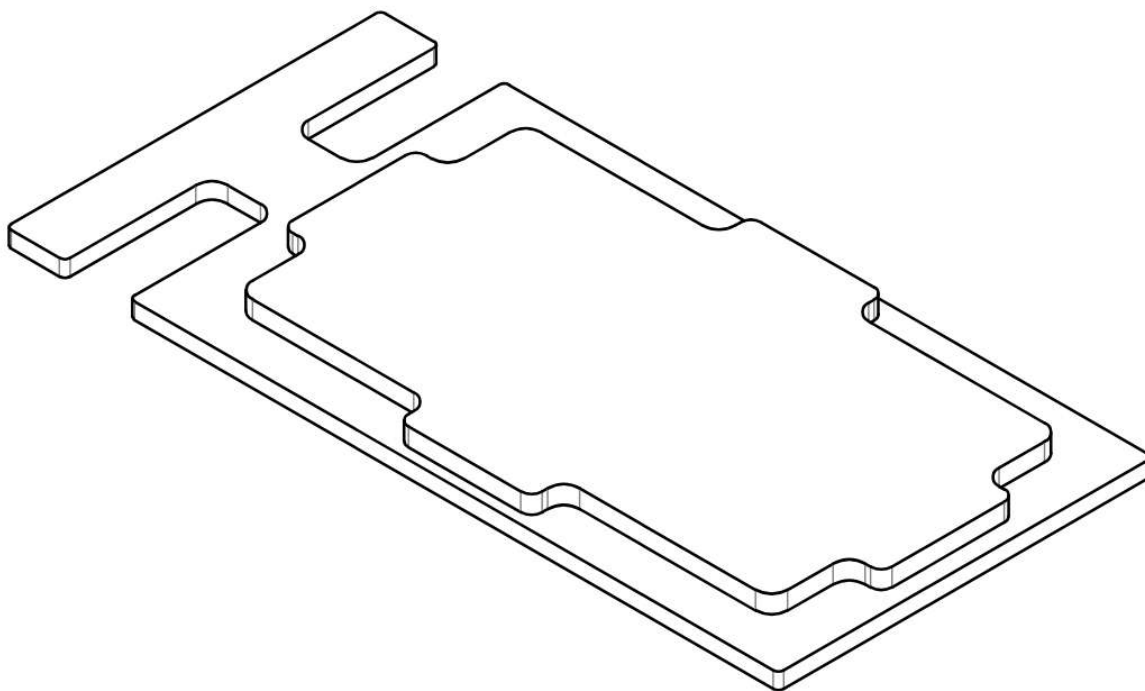

Tampa para Fechamento  
da Coluna PV-003

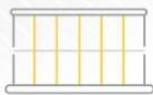

PELE DE  
VIDRO

**ALUMP**<sup>®</sup>  
Extrusão de Alumínio

**VIPEL**<sup>®</sup>  
Vidros e Alumínios

9

PELE DE  
VIDRO  
V-004

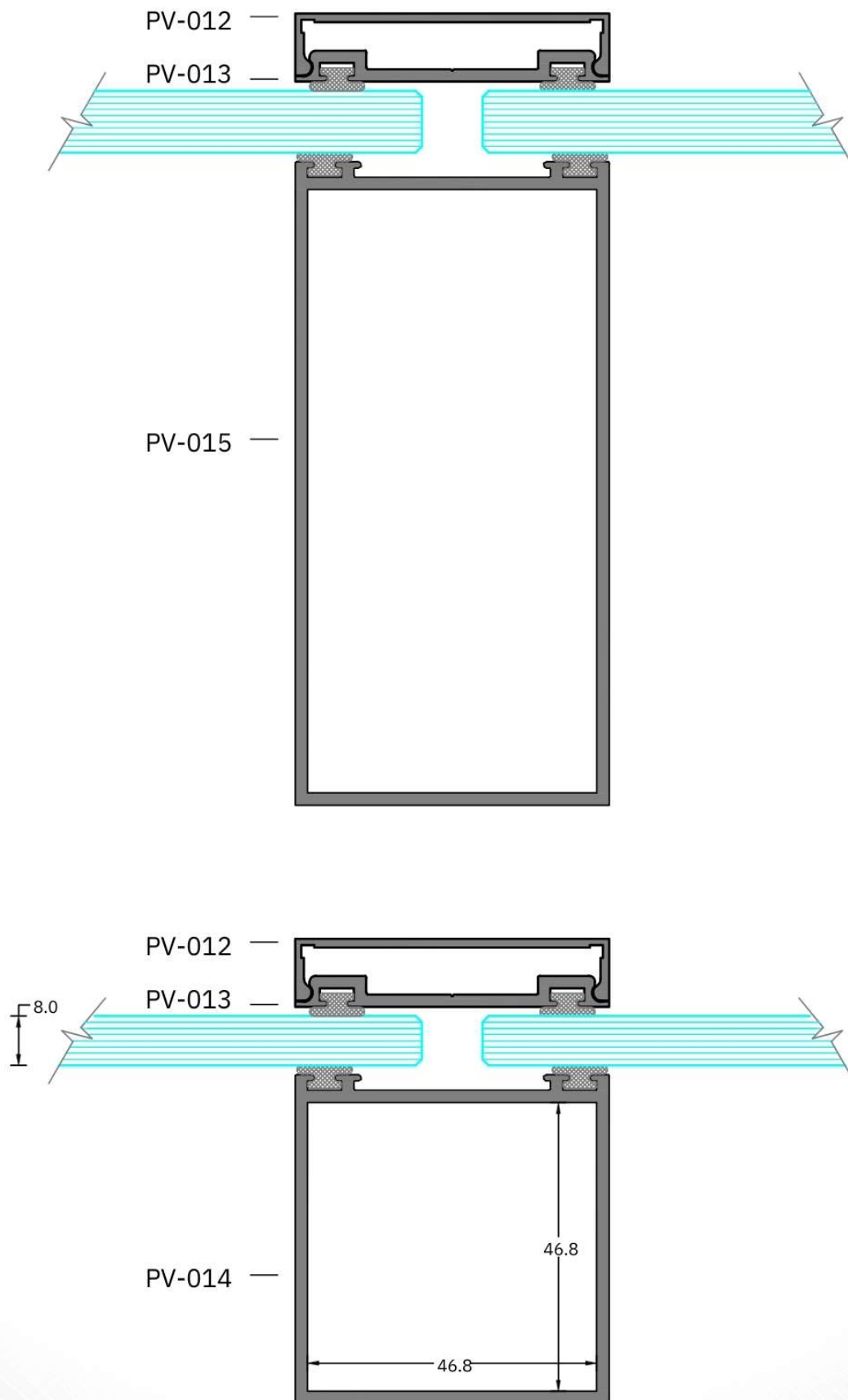

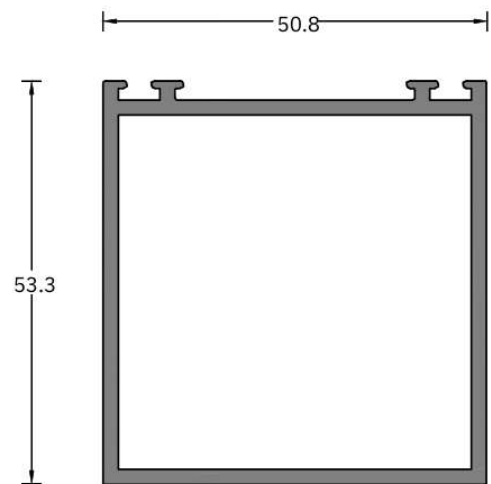
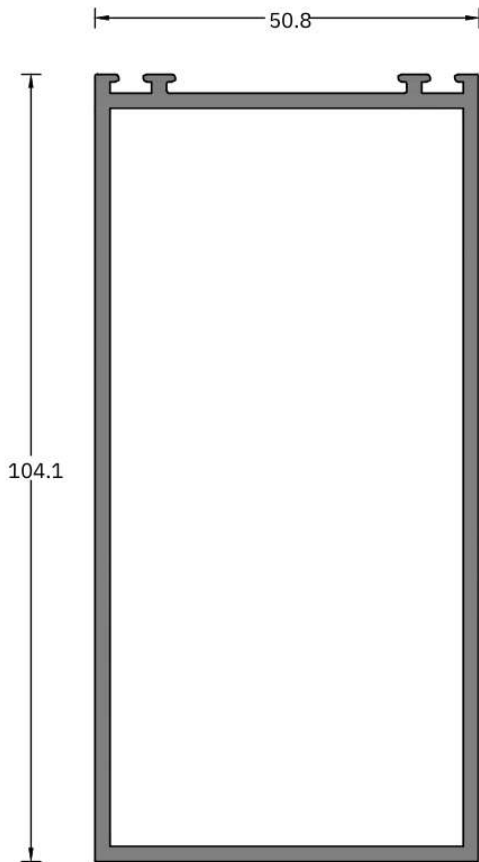
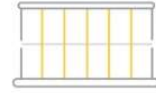

PV-015	Coluna				
	Peso (Kg/m)	Superfície (mm <sup>2</sup> /mm)		Inércia (mm <sup>2</sup> /mm)	
	Área	Perímetro	Jx mm <sup>4</sup>	Jy mm <sup>4</sup>	
	1,680	619.89	624.05	882606.50	287361.00

PV-014	Coluna Intermediária				
	Peso (Kg/m)	Superfície (mm <sup>2</sup> /mm)		Inércia (mm <sup>2</sup> /mm)	
	Área	Perímetro	Jx mm <sup>4</sup>	Jy mm <sup>4</sup>	
	1,129	416.69	420.85	172953.79	172953.79

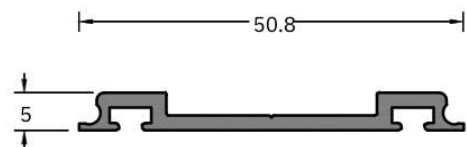
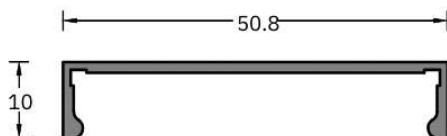

PV-012	Tampa				
	Peso (Kg/m)	Superfície (mm <sup>2</sup> /mm)		Inércia (mm <sup>2</sup> /mm)	
	Área	Perímetro	Jx mm <sup>4</sup>	Jy mm <sup>4</sup>	
	0,263	97.18	144.11	821.85	31053.90

PV-013	Fixador Frontal				
	Peso (Kg/m)	Superfície (mm <sup>2</sup> /mm)		Inércia (mm <sup>2</sup> /mm)	
	Área	Perímetro	Jx mm <sup>4</sup>	Jy mm <sup>4</sup>	
	0,328	121.21	136.98	271.84	27143.70



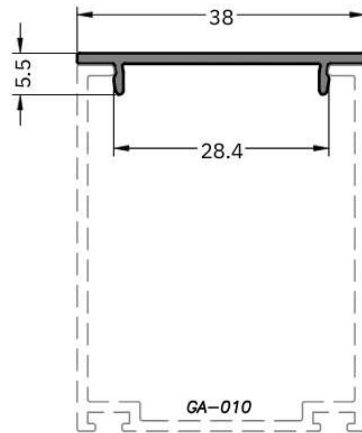
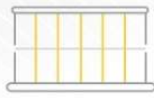

**GA-011** Tampa do Perfil Ripado 38 x 50mm

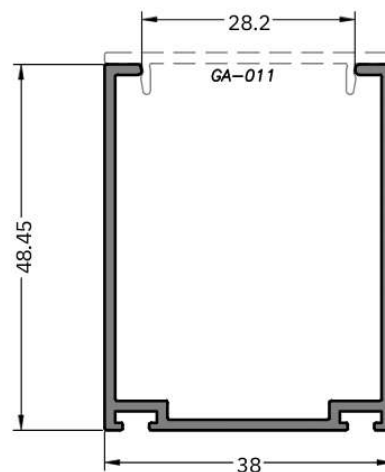
Peso (Kg/m)	Superfície (mm <sup>2</sup> /mml)		Inércia (mm <sup>2</sup> /mml)	
	Área	Perímetro	Jx mm <sup>4</sup>	Jy mm <sup>4</sup>
0,168	61.96	93.51	75.47	7985.40

**GA-010** Perfil Ripado 38 x 50mm

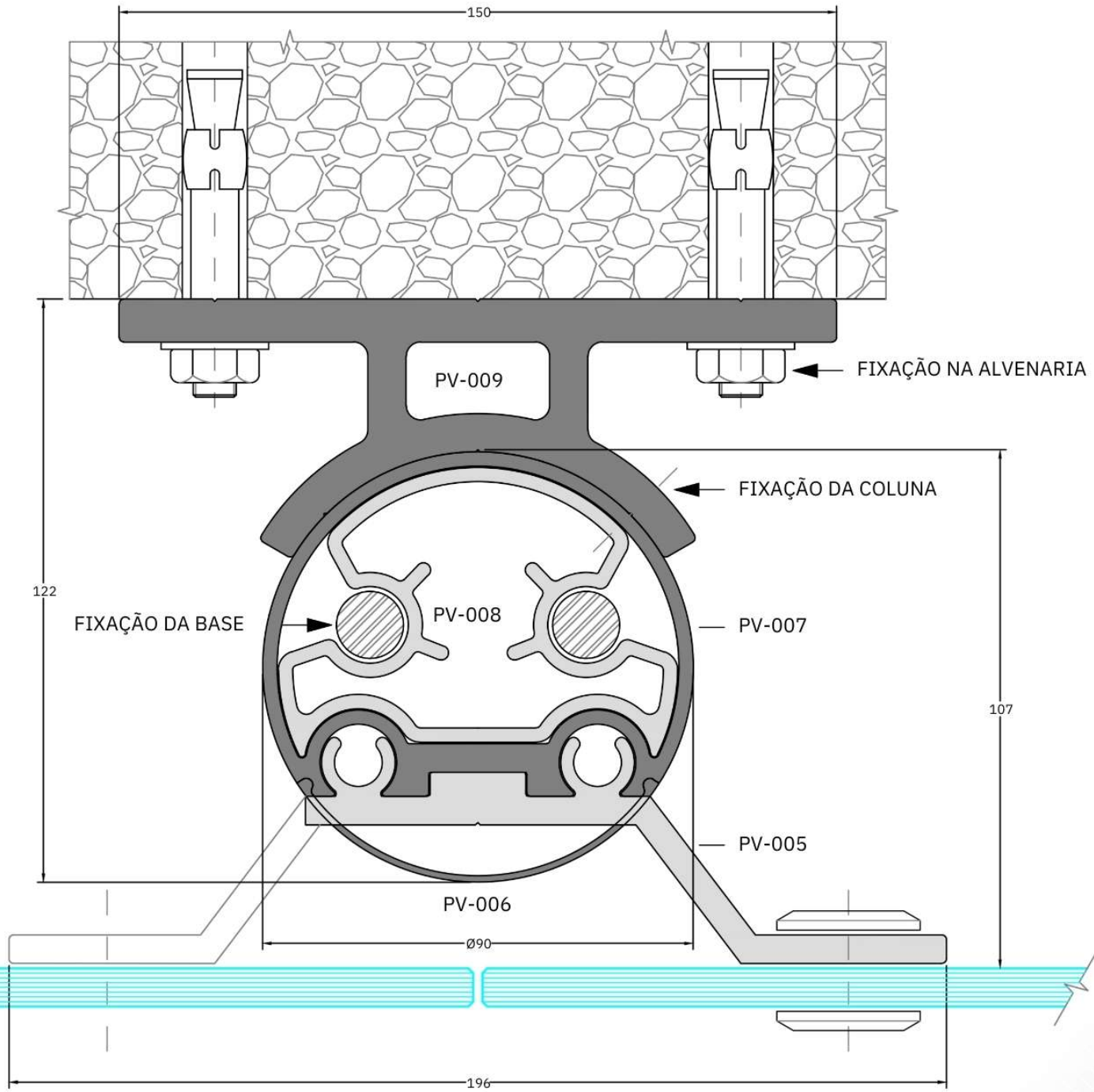
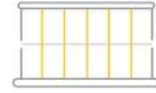
Peso (Kg/m)	Superfície (mm <sup>2</sup> /mml)		Inércia (mm <sup>2</sup> /mml)	
	Área	Perímetro	Jx mm <sup>4</sup>	Jy mm <sup>4</sup>
0,556	205.28	295.45	56459.42	54728.82

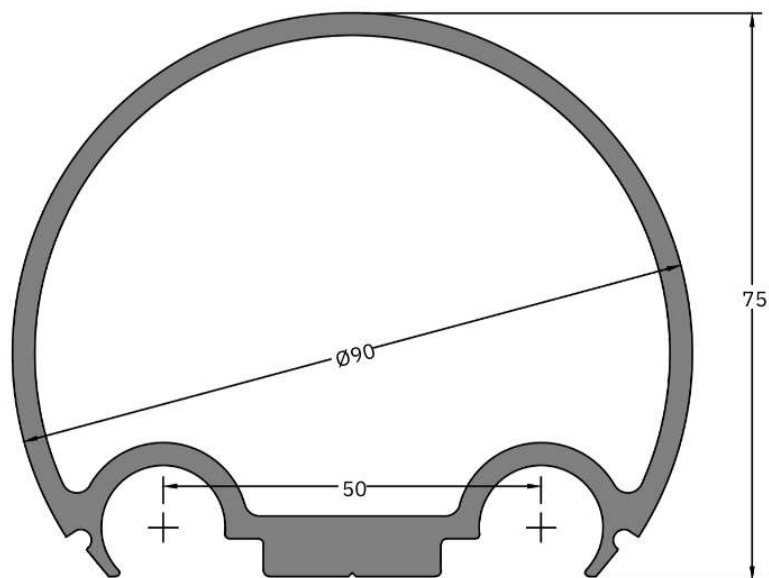



**PV-007** Coluna

Peso (Kg/m)	Superfície (mm <sup>2</sup> /mml)		Inércia (mm <sup>2</sup> /mml)	
	Área	Perímetro	Jx mm <sup>4</sup>	Jy mm <sup>4</sup>
2.658	984.62	585.93	625413.00	815777.98

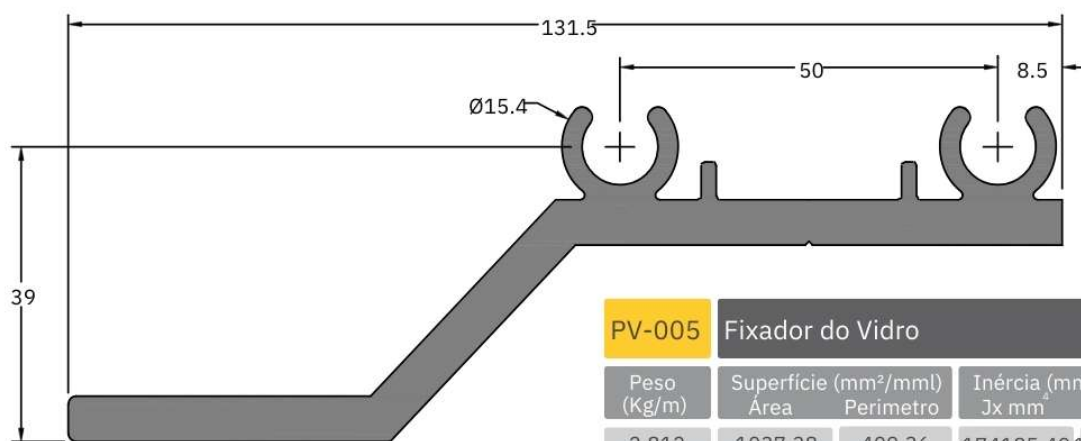

**PV-005** Fixador do Vidro

Peso (Kg/m)	Superfície (mm <sup>2</sup> /mml)		Inércia (mm <sup>2</sup> /mml)	
	Área	Perímetro	Jx mm <sup>4</sup>	Jy mm <sup>4</sup>
2.812	1037.38	409.36	174185.49	1421016.71

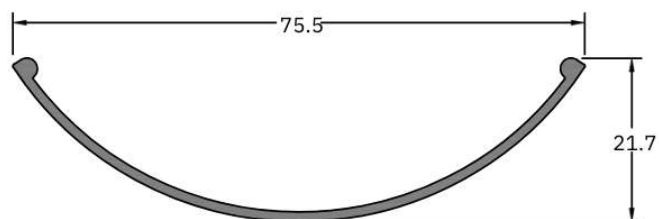

**PV-006** Tampa da Coluna

Peso (Kg/m)	Superfície (mm <sup>2</sup> /mml)		Inércia (mm <sup>2</sup> /mml)	
	Área	Perímetro	Jx mm <sup>4</sup>	Jy mm <sup>4</sup>
0.330	122.07	183.13	5449.86	70379.04



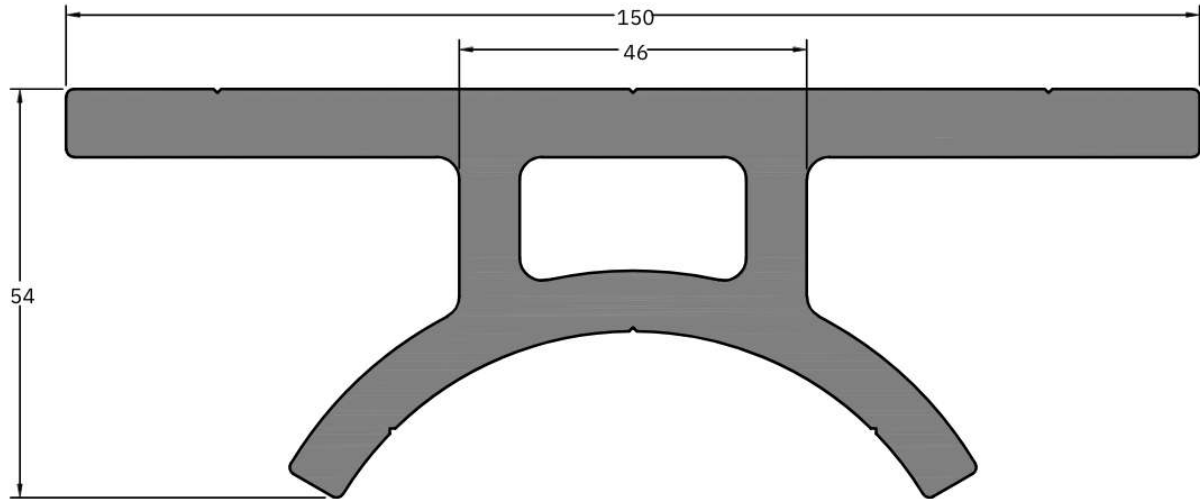

PV-009	Suporte da Coluna				
	Peso (Kg/m)	Superfície (mm <sup>2</sup> /mml) Área Perímetro		Inércia (mm <sup>2</sup> /mml) <sup>4</sup> Jx mm Jy mm	
	6.715	2477.85	568.83	581593.47	3214896.95

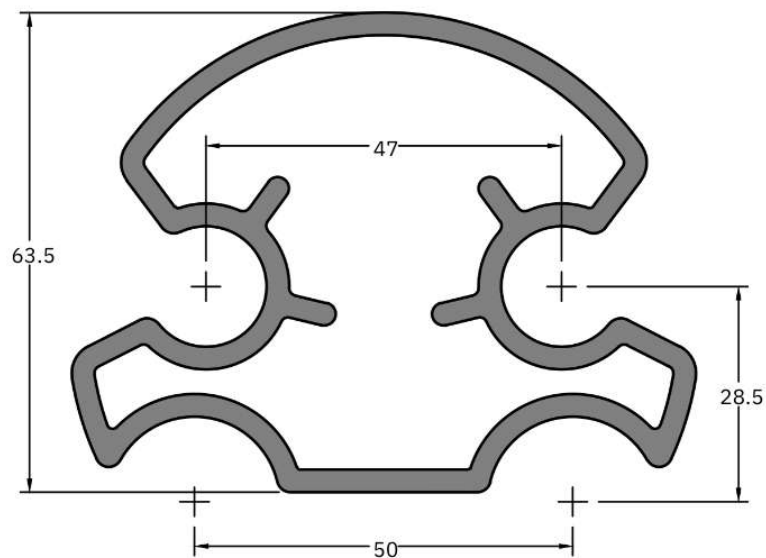

PV-008	Chumbador				
	Peso (Kg/m)	Superfície (mm <sup>2</sup> /mml) Área Perímetro		Inércia (mm <sup>2</sup> /mml) <sup>4</sup> Jx mm Jy mm	
	2.788	1025.94	672.38	371666.17	591097.88